

MMPH

INDUSTRIES®

Installation Guide





Ford Interceptor SUV Bracket Combo Assembly

FITS: BEE III, Enforcer, Python III, Ranger

PT#

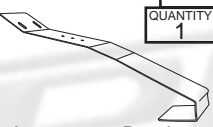
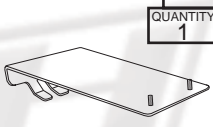
ai.951693

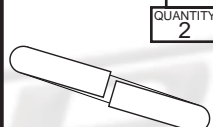
Installation Materials

910731P01 A QUANTITY 1  Interceptor Bracket (front)	910731P02 B QUANTITY 1  Interceptor Bracket (back)	400010 C QUANTITY 2  6-32 Wing Nut	408048 D QUANTITY 2  Regular Plain Washer #6	408049 E QUANTITY 2  Lock Split Washer #6	408035 F QUANTITY 2  Nylon Plain Washer #6
--	---	--	---	---	--

ai.951693

SUBSTRUCTURE 1

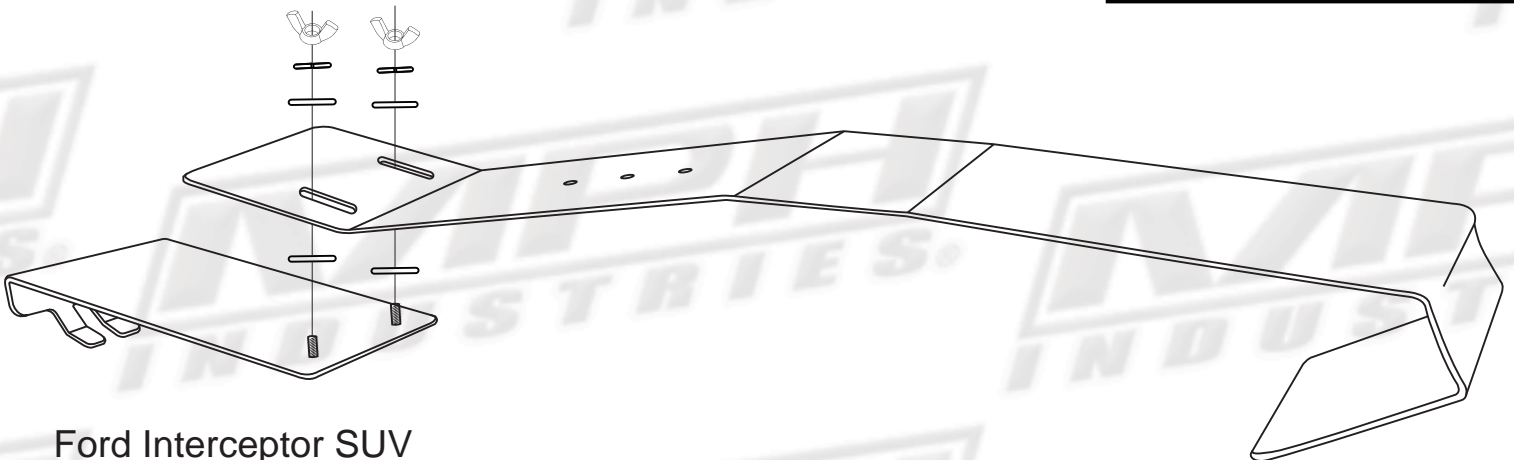

Ford Interceptor SUV
Bracket Combo Assembly





MMPH

INDUSTRIES®

Installation Guide BEE III Bracket Cradle Assembly

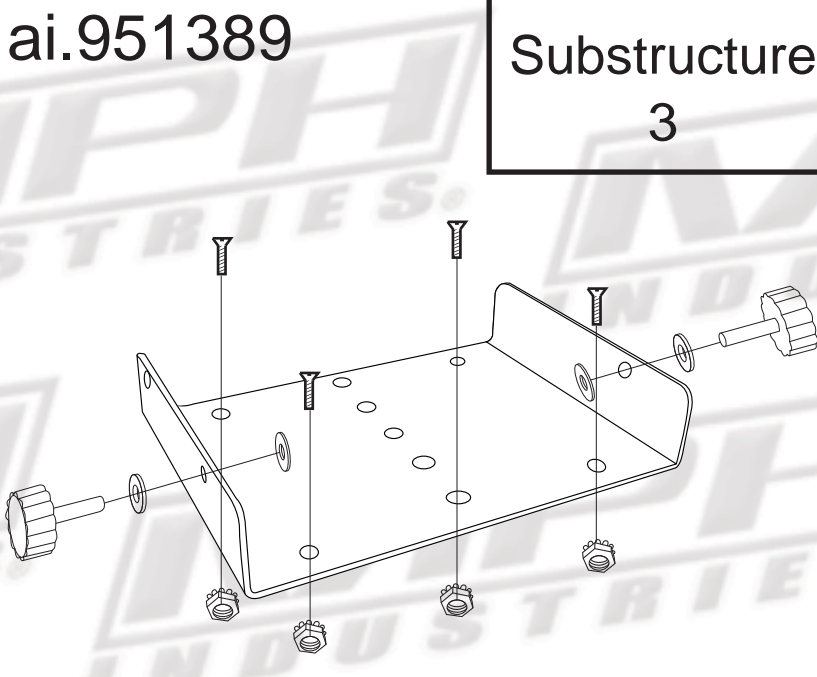
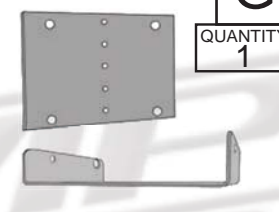
PT# ai.951389

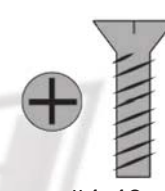
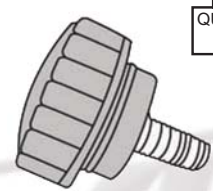
Installation Materials

<p>ai.951389</p> <p>Substructure 3</p>  <p>BEE III Bracket Cradle</p>	<p>910102</p> <p>G</p> <p>QUANTITY 1</p>  <p>Display Bracket</p>	<p>908338</p> <p>!</p> <p>QUANTITY 4</p>  <p>#4-40 KEP Nut</p>
	<p>908338</p> <p>H</p> <p>QUANTITY 4</p>  <p>#4-40x.25 Flat Head Screw</p>	<p>909094</p> <p>I</p> <p>QUANTITY 2</p>  <p>10-32 Stud Knob</p>
	<p>900092</p> <p>J</p> <p>QUANTITY 4</p>  <p>Flat Nylon Washer #10</p>	<p>Not used with Part# 951693</p>



MMPH

INDUSTRIES®

Installation Guide Python III & Ranger Bracket Cradle Assembly

PT# ai.951388

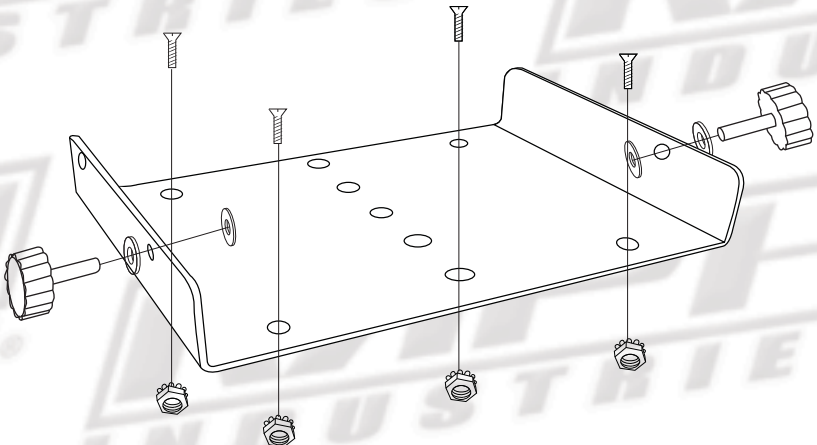
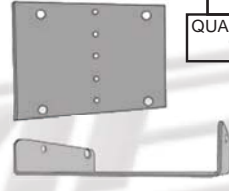
Installation Materials

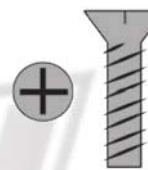
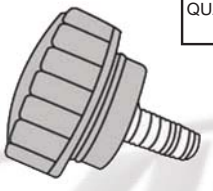
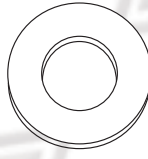
<p>ai.951388</p> <p>Substructure 2</p>  <p>Python III, Ranger Bracket Cradle</p>	<p>909965</p> <p>G</p> <p>QUANTITY 1</p>  <p>Display Bracket</p>	<p>908338</p> <p>!</p> <p>QUANTITY 4</p>  <p>#4-40 KEP Nut</p>
	<p>903772</p> <p>H</p> <p>QUANTITY 4</p>  <p>#4-40x.312 Flat Head Screw</p>	<p>909094</p> <p>I</p> <p>QUANTITY 2</p>  <p>10-32 Stud Knob</p>
	<p>900092</p> <p>J</p> <p>QUANTITY 4</p>  <p>Flat Nylon Washer #10</p>	<p>Not used with Part# 951693</p>

Installation Process

1

Taking the Back Bracket (B) place a Regular Plain Washer (D) on each stud.

2

Place the Front Bracket (A) on top of the Back Bracket (B). On each stud fit a Nylon Plain Washer (F) followed by a Lock Split Washer (E). Secure the two brackets, but not fully tighten, with a Wing Nut (C).

3

Using Substructure 2 or 3 materials place the Display Bracket (G) on top of the Front Bracket (A). Line up the three mounting holes on each bracket and screw in place with three Flat Top Screws (H).

4

Mount bracket into vehicle by first placing the Back Bracket (B) into the defrost vents and overlapping the Front Bracket (A) over the front of the dash. Push together the two mounts and tighten the Wing Nuts (C) holding the two brackets firmly together.

5

Taking both Stud Knobs (I), place a Nylon Flat Washer (J) onto the stud. Put through the holes of the Display Bracket (G). Add another Nylon Flat Washer (J) separating the unit from the Display Bracket (G). Put the radar unit into place. Secure with studs.

6

Adjust the read-out unit using the Stud Knobs (I). Check all fastening pieces to be sure that the bracket and read-out are secure.

7

Ford Interceptor SUV
Bracket Assembly
Part# ai.951689

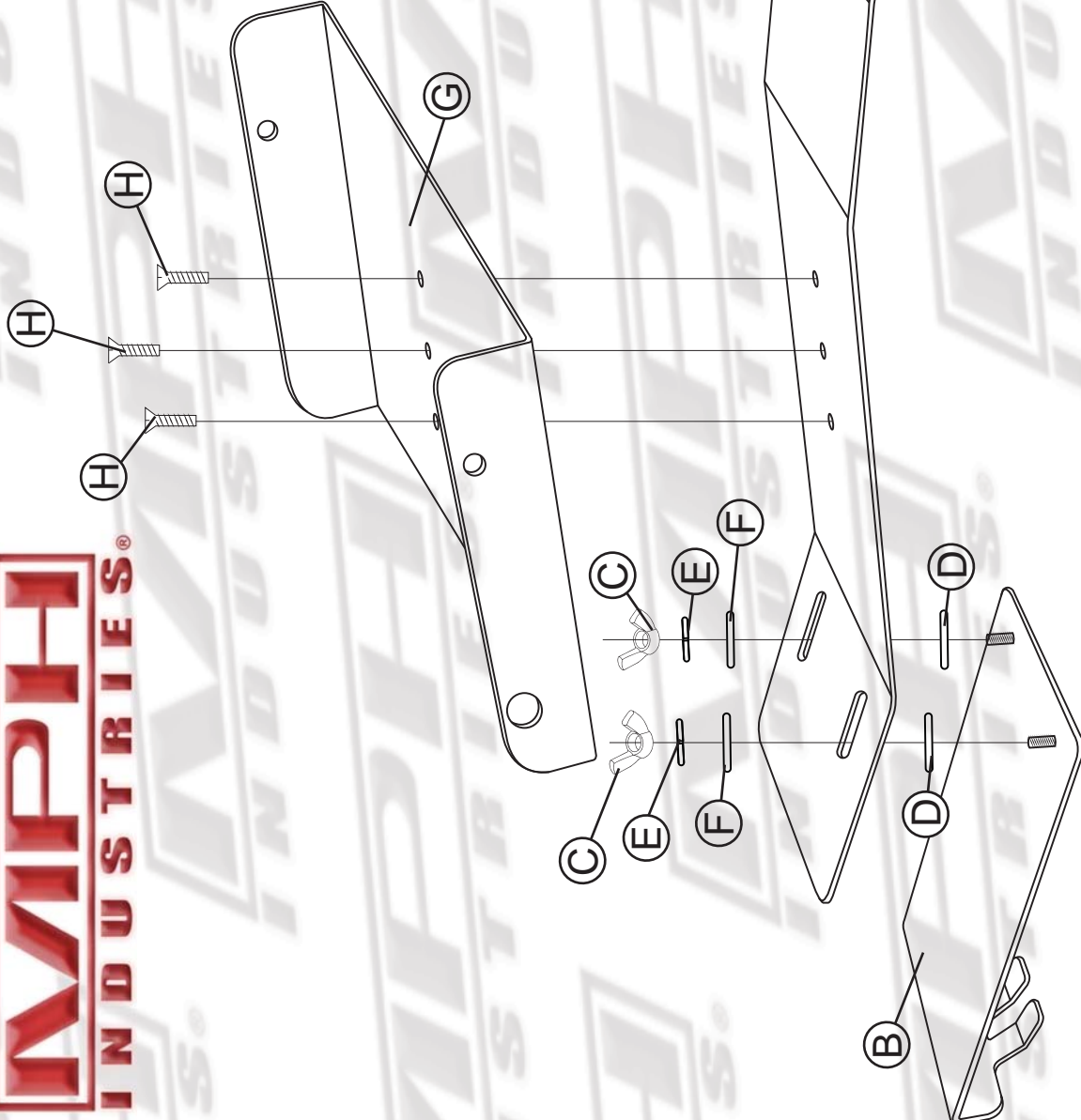
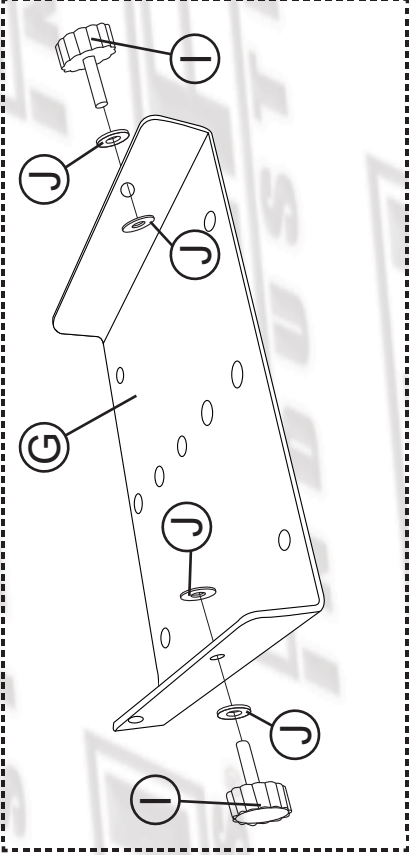

ITEM	QUANTITY	PART NUMBER	DESCRIPTION
G	1	910102	BEE III Display Bracket
G	1	909965	Python III, Ranger Display Bracket
H	4	903772	#4-40 Flat Hd. Screw
I	2	909094	10-32 Stud Knob
J	4	900092	Flat Nylon Washer #10

ITEM	QUANTITY	PART NUMBER	DESCRIPTION
A	1	910731P01	Interceptor Bracket (front)
B	1	910731P02	Interceptor Bracket (back)
C	2	400010	6-32 Wing Nut
D	2	408048	Regular Plain Washer #6
E	2	408049	Lock Split Washer #6
F	2	408035	Nylon Plain Washer #6