

MMPH INDUSTRIES®



Installation Guide Antenna Visor Mount Bracket Assembly

FITS: BEE III, Enforcer, Python III, Ranger

PT# ai.950961

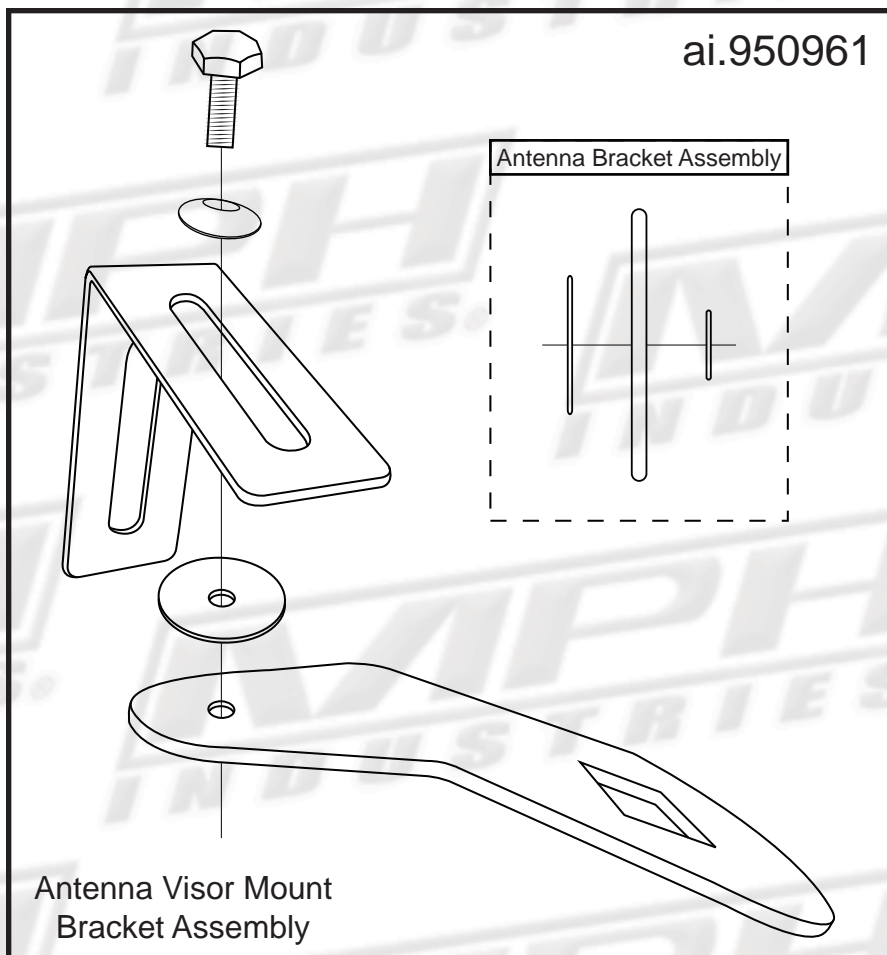
Installation Materials

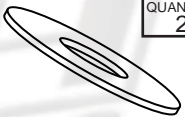
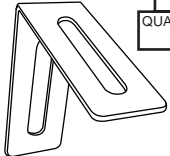
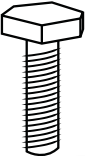

909436  Visor Mount Bracket	A QUANTITY 1	900024  Nylon Washer .219 x 1.0 x .03	B QUANTITY 2
909106  Angle Antenna Bracket	C QUANTITY 1	903543  Hex Screw 1/4-20 x .62	D QUANTITY 1
903356  Nylon Flat Washer 1/4" x .032	E QUANTITY 1	900025  Disc Spring Washer	F QUANTITY 1

Installation Process

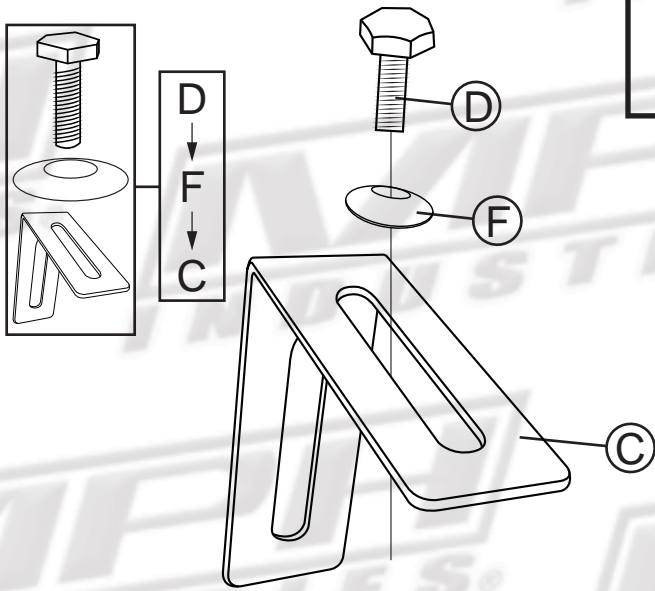

1

Take the Hex Screw (D) and place a Disc Spring Washer (F) on to the stud. Fit through the hole of the Angle Bracket (B).

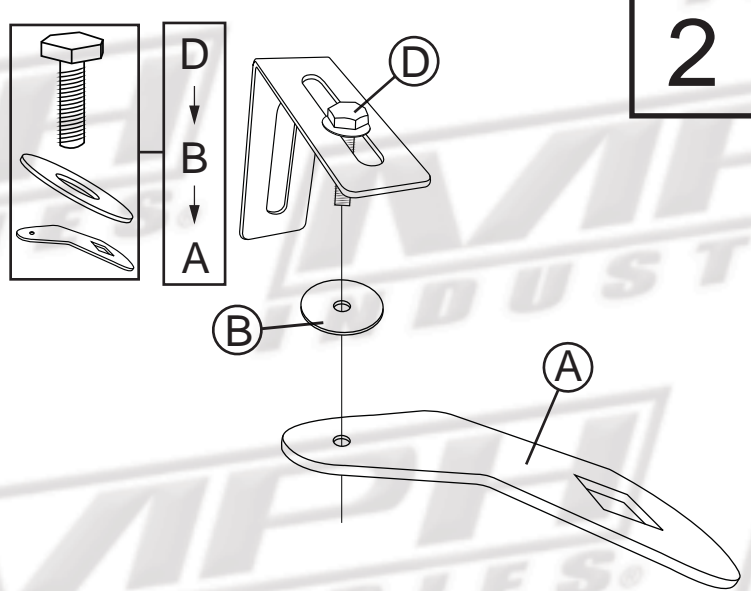

2

Twist a Nylon Washer (B) onto the Hex Screw (D) stud. Thread the Visor Mount Bracket (A) to the Hex Screw (D).

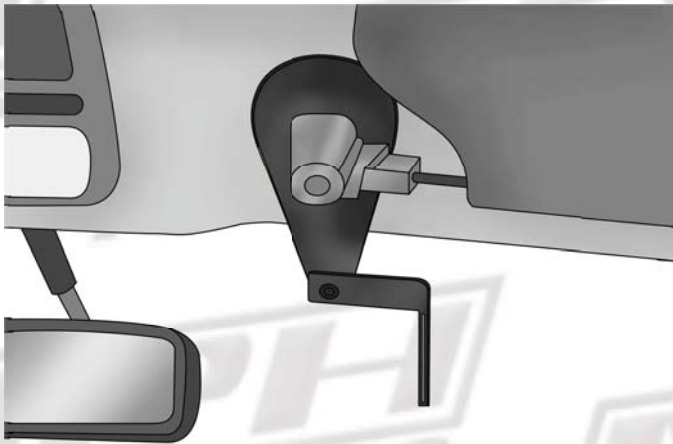

3

Remove the screw from one of the visor mounts of the car. Put the Visor Mount Bracket (A) where the visor mount was. Replace the piece to hold together the finished bracket.

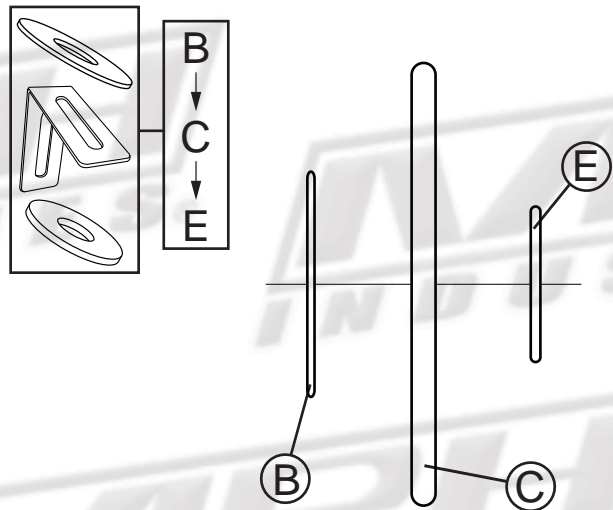

4

Place a Nylon Washer (B) onto the stud of the antenna. Fit the stud through the slotted side of the Angle Bracket (C) followed by the Flat Nylon Washer (E).

5

Antenna Visor

Bracket Mount Assembly
Part# ai.950961

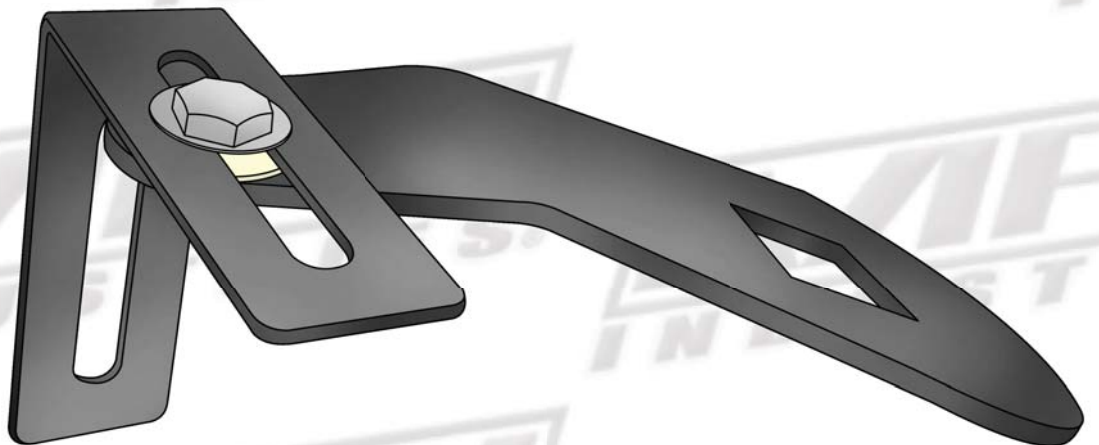

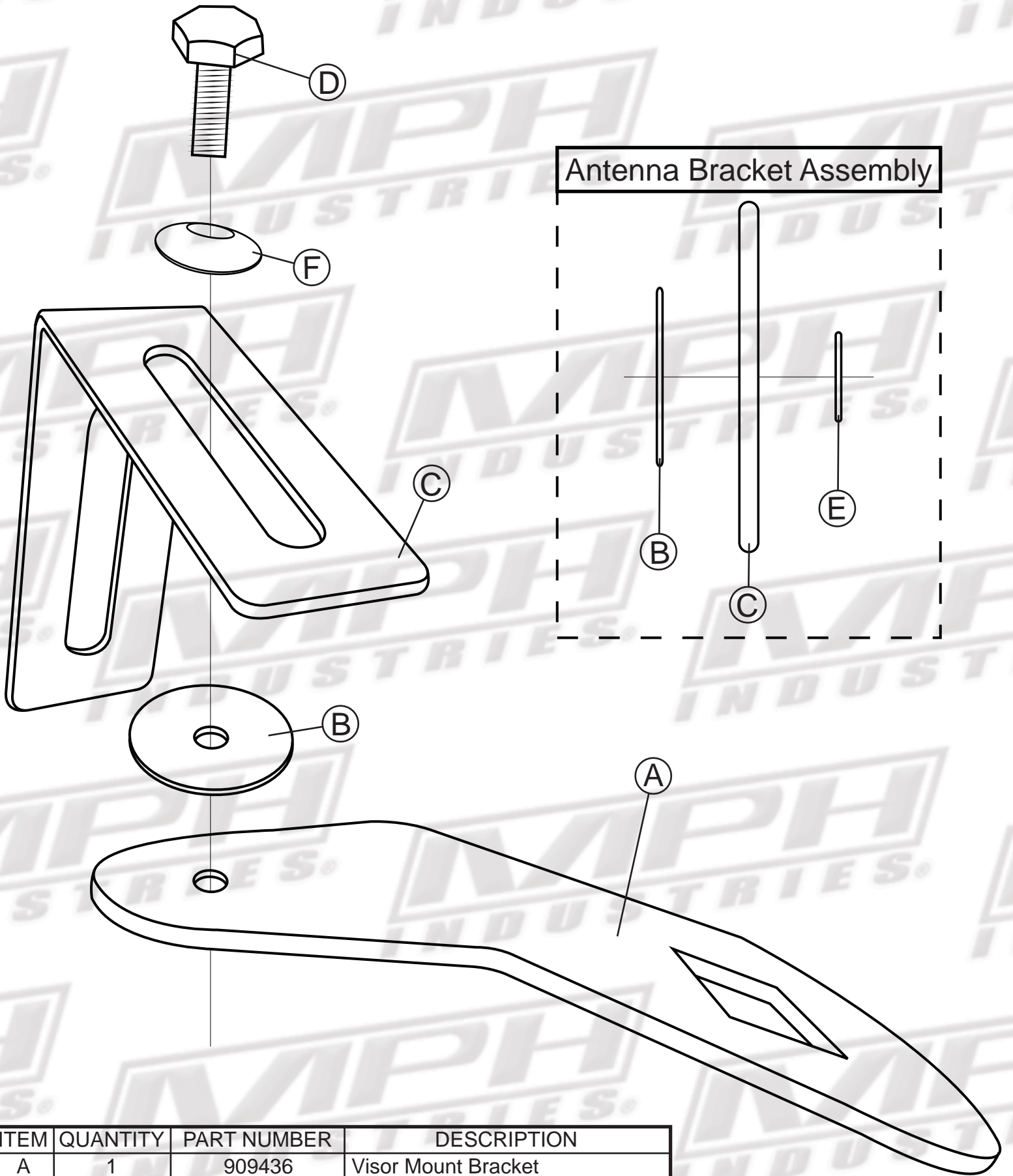

Antenna Bracket Assembly

ITEM	QUANTITY	PART NUMBER	DESCRIPTION
A	1	909436	Visor Mount Bracket
B	2	900024	Nylon Washer .219 x 1.0 x .03
C	1	909106	Angle Antenna Bracket BEE III
D	1	903543	Hex Screw 1/4-20 x .62
E	1	903356	Flat Nylon Washer 1/4" x .032
F	1	900025	Disc Spring Washer