

MMPH INDUSTRIES®







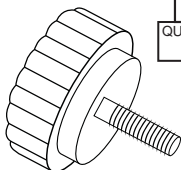
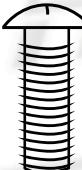

Installation Guide Harley Davidson Handlebar Bracket

FITS: BEE III & ENFORCER

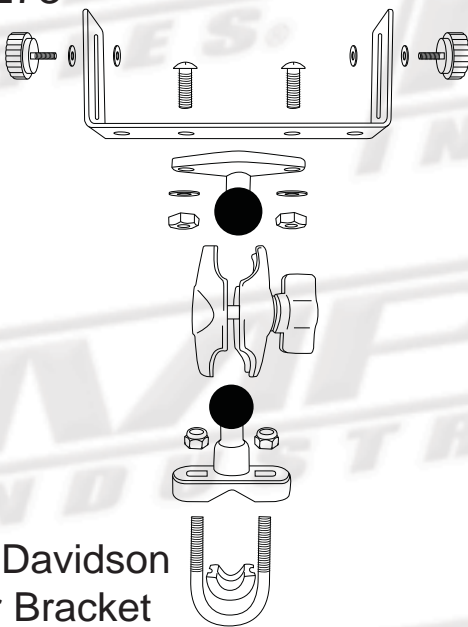
PT#

ai.951273

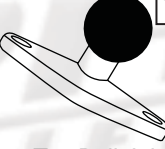
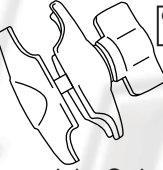
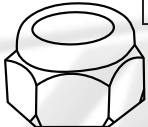
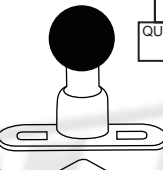
Installation Materials

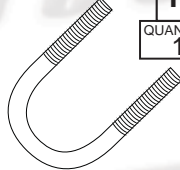
<p>909351</p> <p>A</p> <p>QUANTITY 1</p>  <p>Display Bracket</p>	<p>909094</p> <p>B</p> <p>QUANTITY 2</p>  <p>Stud Knob 10-32</p>	<p>401804</p> <p>C</p> <p>QUANTITY 2</p>  <p>Screw 10-32x .500</p>	<p>909092</p> <p>D</p> <p>QUANTITY 2</p>  <p>Flat Nylon Washer #10</p>
<p>ai.951273</p>  <p>Harley Davidson Radar Bracket</p>	<p>908827</p> <p>E</p> <p>QUANTITY 2</p>  <p>KEP Hex Nut</p>	<p>908203</p> <p>F</p> <p>QUANTITY 2</p>  <p>Regular Washer #10</p>	<p>908089</p> <p>G</p> <p>QUANTITY 2</p>  <p>Lock Tooth Washer #10</p>
	<p>SEE BOTTOM</p> <p>H</p> <p>QUANTITY 1</p>  <p>Top Ball Joint</p>	<p>SEE BOTTOM</p> <p>I</p> <p>QUANTITY 1</p>  <p>Joint Swivel</p>	<p>SEE BOTTOM</p> <p>J</p> <p>QUANTITY 2</p>  <p>Nut</p>
	<p>SEE BOTTOM</p> <p>K</p> <p>QUANTITY 1</p>  <p>Bottom Ball Joint</p>	<p>SEE BOTTOM</p> <p>L</p> <p>QUANTITY 1</p>  <p>Bushing</p>	<p>SEE BOTTOM</p> <p>M</p> <p>QUANTITY 1</p>  <p>U-Bolt *different sizes available</p>

**Parts H-M/ Part# 909353
Harley Davidson Short Arm Bracket

Installation Process

1

Place the Top Ball Joint (H) on the bottom of the Display Bracket (A), lining up the two bolt holes.

2

Lining up the holes on the Display Bracket (A) and the Top Ball Joint (H), place the Screw (C) through the top of the Display Bracket (A). Fit Lock Tooth Washer (G) on the bolt followed by a KEP Hex Nut (E). Tighten.

3

Using the Joint Swivel (I) fit both Ball Joints (H)(K) onto either side. Tighten the Joint Swivel (I) to safely hold parts together, do not tighten.

4

Once the bracket is firmly built, fit Bushing (L) in the middle of the U-Bolt (M). Take the U-Bolt (M) and fit it under the handle bar of the motorcycle so the Bushing (L) is directly on the surface. Place the bracket on top of the U-Bolt (M) through the holes on the Bottom Ball Joint (K). Secure using the Nut (J) provided. Tighten in place.

5

Place the radar unit onto the Display Bracket (A). Fit a Regular Washer (F) onto a Stud Knob (B). Placing a Nylon Washer (D) between the radar unit and the Display Bracket (A). Repeat for other side.

6

Loosen Knobs & Joint Swivel

When Finished, the radar unit can be adjusted by loosening the Stud Knobs (B) and moving the radar unit in the direction preferred by the person. Also loosening the Joint Swivel (I) and moving the Display Bracket (A) to your preference.

7

Harley Davidson

Bracket Assembly
Part# ai.951273

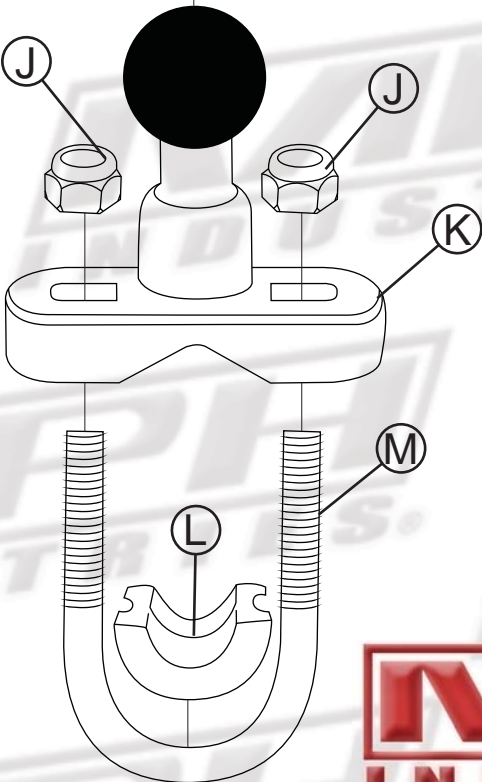
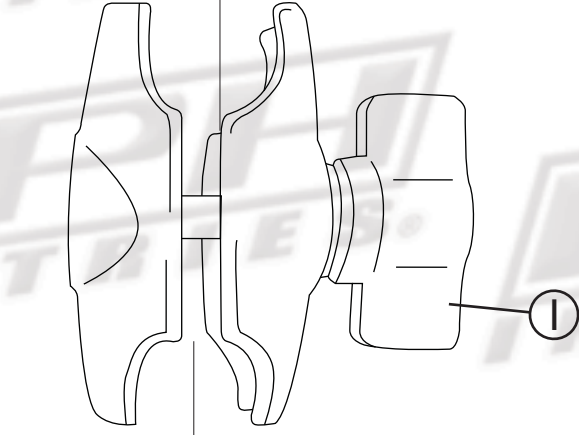
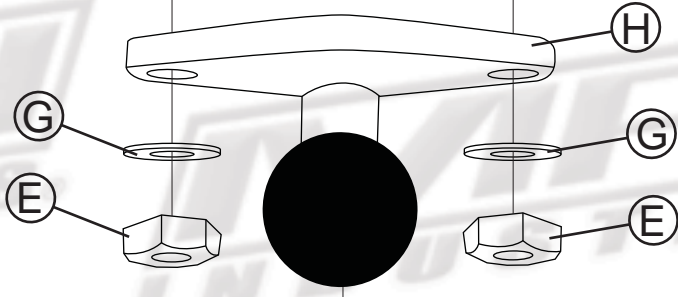
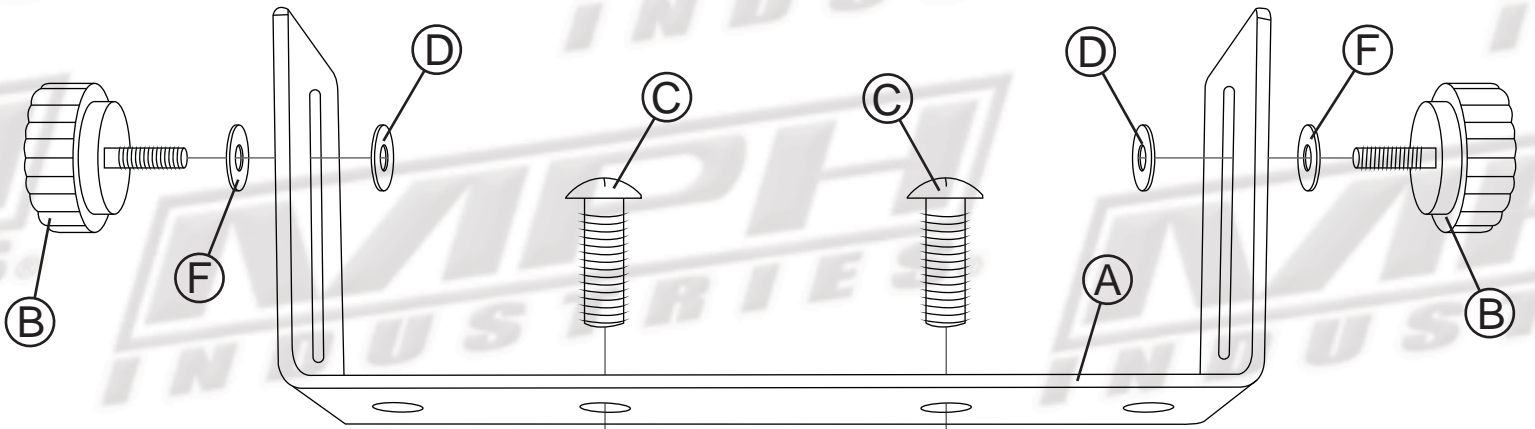

ITEM	QUANTITY	PART NUMBER	DESCRIPTION
A	1	909351	Display Bracket
B	2	909094	Stud Knob 10-32
C	2	401804	Screw 10-32x .500
D	2	909092	Flat Nylon Washer #10
E	2	908827	KEP Hex Nut
F	2	908203	Regular Washer #10
G	2	908089	Lock Tooth Washer #10
H	1	**909353	Top Ball Joint
I	1	**909353	Joint Swivel
J	2	**909353	Nut
K	1	**909353	Bottom Ball Joint
L	1	**909353	Bushing
M	1	**909353	U-Bolt

