

# MMPH

## INDUSTRIES®









### Installation Guide

### BEE III/Enforcer

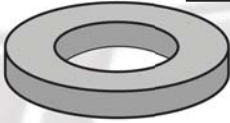
### Dash & Antenna Bracket

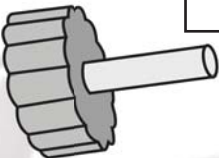
### Assembly

### Installation Materials

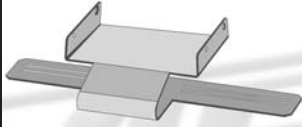
909090  Flat Head Screw	A QUANTITY 1	909092  #10 Nylon Flat Washer	B QUANTITY 5	908203  #10 Flat Washer	C QUANTITY 3	908340  1/4" Flat Washer	D QUANTITY 1	903356  1/4" Nylon Flat Washer	E QUANTITY 1
909094  10-32 Knob w/ Stud	F QUANTITY 2	909091  10-32 Knob w/ Insert	G QUANTITY 1	909085  1/4-20 Star Knob w/ Insert	H QUANTITY 1	909807G01  Antenna Bracket	I QUANTITY 1	909041  Dash Bracket	J QUANTITY 1

PT#  
ai.950955  
&  
ai.951250

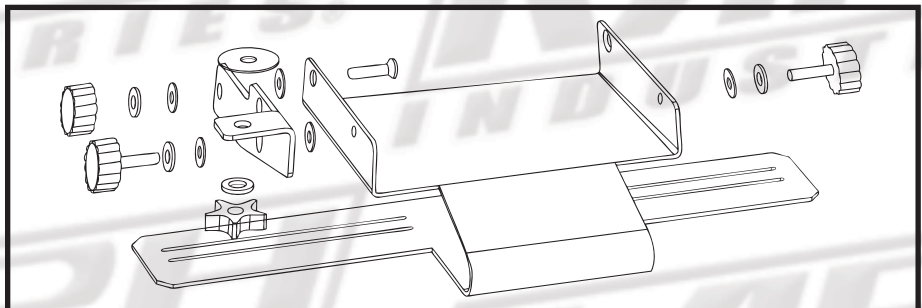
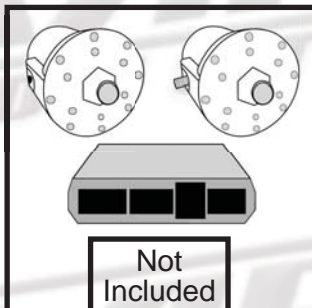

# Installation Process

1

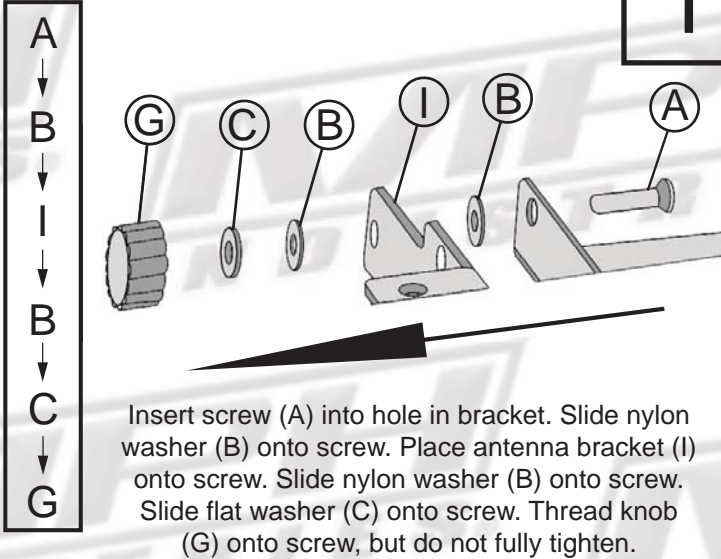

Insert screw (A) into hole in bracket. Slide nylon washer (B) onto screw. Place antenna bracket (I) onto screw. Slide nylon washer (B) onto screw. Slide flat washer (C) onto screw. Thread knob (G) onto screw, but do not fully tighten.

2

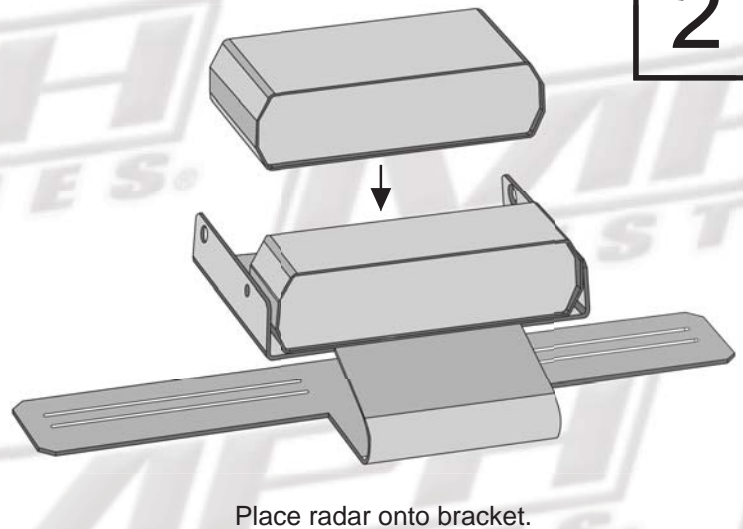

Place radar onto bracket.

3

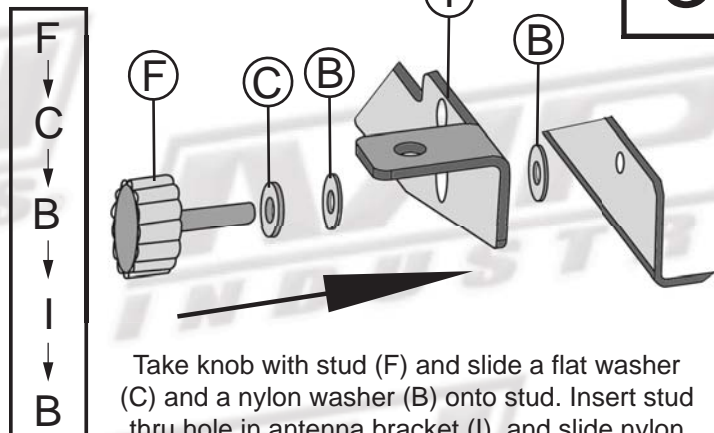

Take knob with stud (F) and slide a flat washer (C) and a nylon washer (B) onto stud. Insert stud thru hole in antenna bracket (I), and slide nylon washer (B) onto the stud. Thread knob into insert in the side of the radar. Repeat for other side of bracket.

4

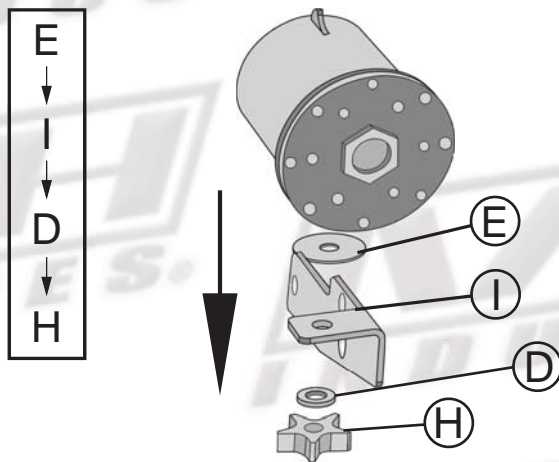

Take antenna and place large nylon (E) washer onto the stud in the antenna. Insert stud from the antenna thru hole in antenna bracket (I). Slide flat washer (D) onto antenna stud and secure with star knob (H).

5

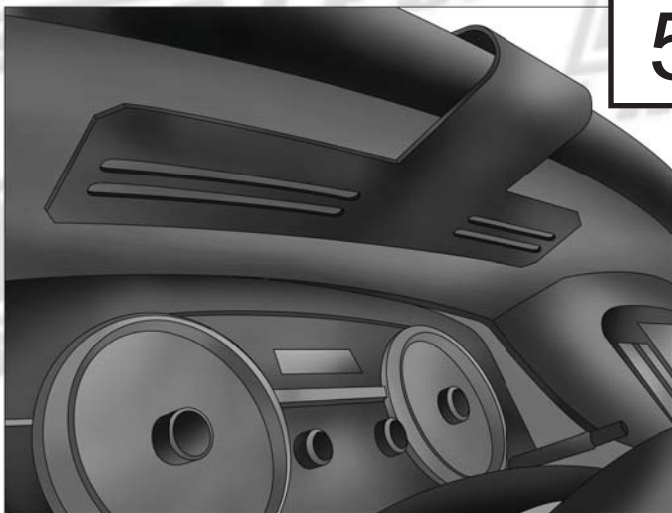

Look on the underside of the dash where the instrument panel is located and find two screws. Remove the screws from the dash.

6



Take assembled bracket and place it above the steering wheel, so that the slots in the dash bracket (J) line up with screw holes. Thread screw back into the dash to secure your bracket and radar. The bottom of the bracket is made to bend in order to conform to your dash. Fully tighten all knobs.



# MFI INDUSTRIES®

ITEM	QUANTITY	PART NUMBER	DESCRIPTION
A	1	909090	10-32 x 0.50 Flat Head Screw
B	5	909092	#10 Nylon Flat Washer
C	3	908203	#10 Flat Washer
D	1	908340	1/4" Flat Washer
E	1	903356	1/4" Nylon Flat Washer
F	2	909094	10-32 Knob With Stud
G	1	909091	10-32 Knob With Insert
H	1	909085	1/4 - 20 Star Knob With Insert
I	1	909807G01	Bee III/Enforcer Antenna Bracket
J	1	909041	Bee III/Enforcer Dash Bracket

