

MMPH

INDUSTRIES®







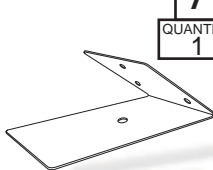
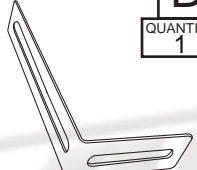

Installation Guide

Display and Antenna Bracket Assembly

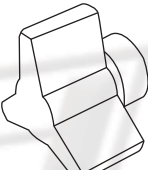
FITS: Ranger, Python III, BEE III, Enforcer

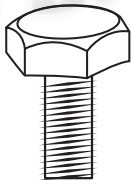
PT# ai.951052

Installation Materials

| | | | |
|---|---|--|--|
| 909255 A QUANTITY 1  Display Bracket | 909256 B QUANTITY 1  Angle "L" Antenna Bracket | 909265 C QUANTITY 3  Suction Cup Assembly | 909085 D QUANTITY 1  Female Star Knob 1/4-20 |
| 900024 E QUANTITY 2  Nylon Washer 1/4" | 900025 F QUANTITY 2  Disc Spring Washer | 903543 G QUANTITY 1  Screw 1/4-20 x 1.00 | |
| 908036 H QUANTITY 1  Wing Nut 1/4-20 | 908340 I QUANTITY 2  Flat Washer 1/4" | 908601 J QUANTITY 2.8 in  Double-Coated Tape | |

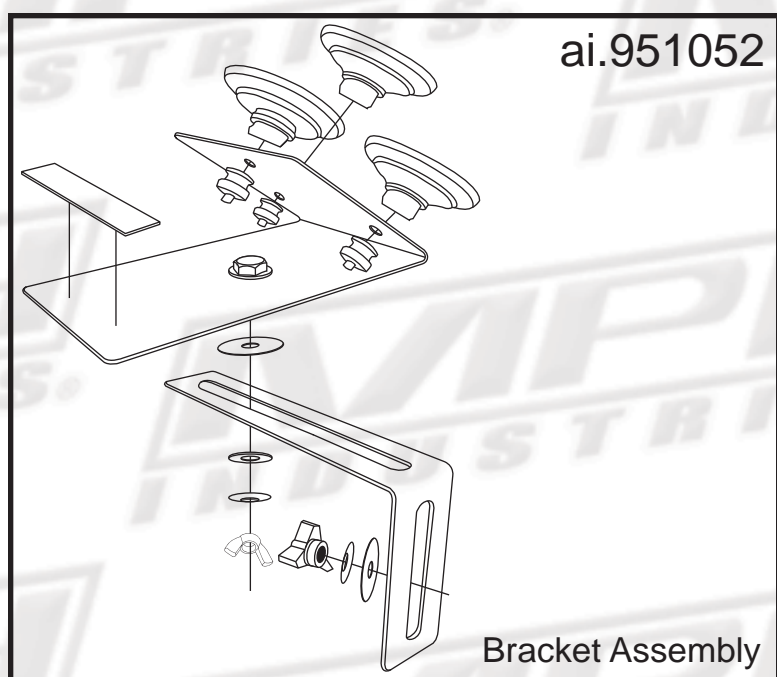

Installation Process

1

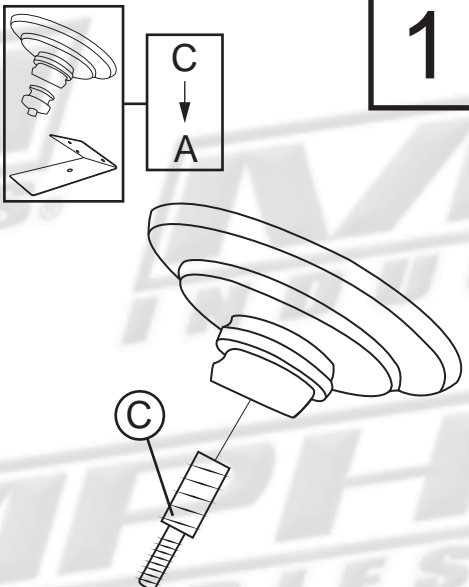

Using the Suction Cup Assembly (C), thread a stud into the suction cups. Put the stud into the holes of the shorter end of the Display Bracket (A).

2

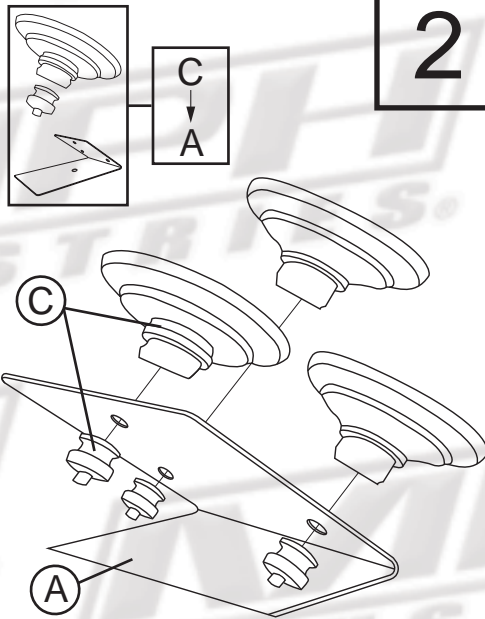

Use the metal threaded caps to secure the suction cups to the Display Bracket (A).

3

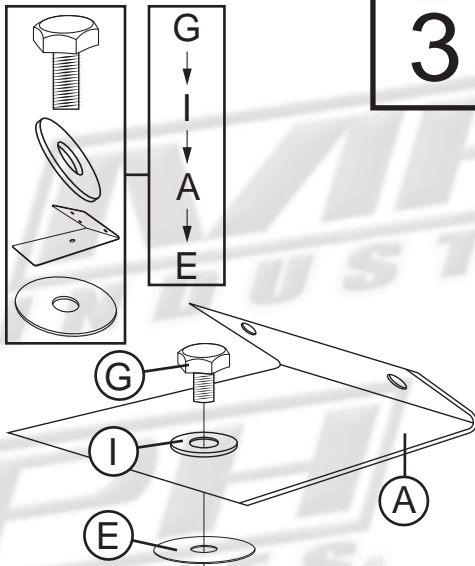

Locate one of the Flat Washers (I) and place it on the Screw (G). Insert the Screw (G) into the hole in the Display Bracket (A). Twist a Nylon Washer (E) onto the Screw (G).

4

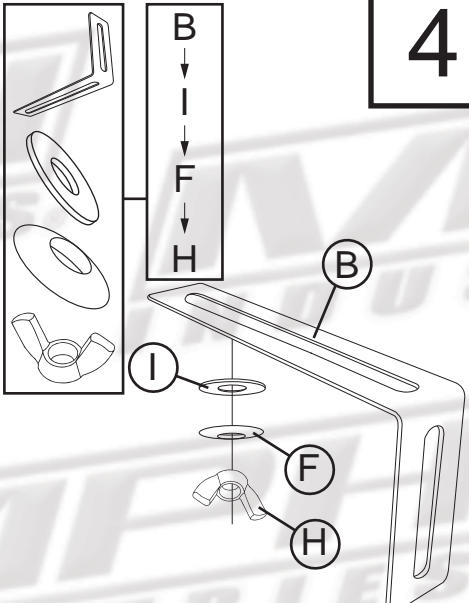

Place the long end of the Angle Bracket (B) over the Nylon Washer (E). Drop a Flat Washer (I) onto the Screw (G) followed by a Disc Washer (F). Secure using the Wing Nut (H).

5

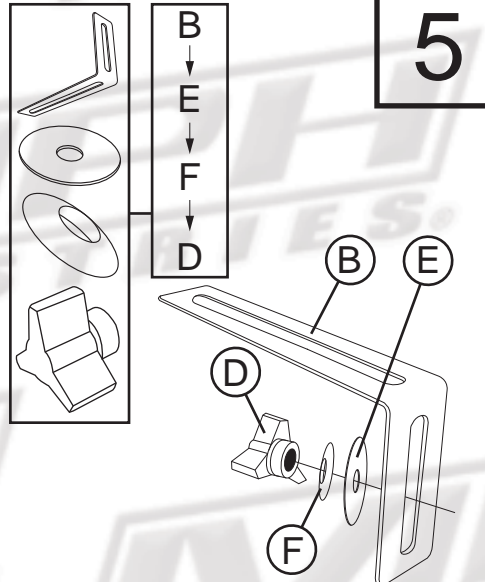

Using the stud from the antenna, insert it through slot of the Angle Bracket (B). Twist a Nylon Washer (E) onto the antenna stud. Place a Disc Washer (F) over the Nylon Washer (E), securing the antenna with the Star Knob (D).

6

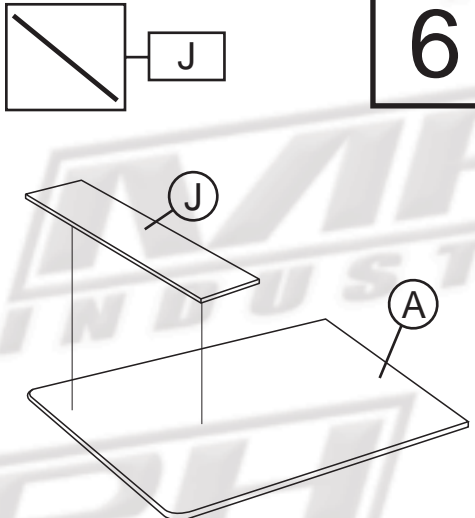

Peel backing from Double-Coated Tape (J) and press radar display onto tape.

7

Bracket Assembly

Part# ai.951052



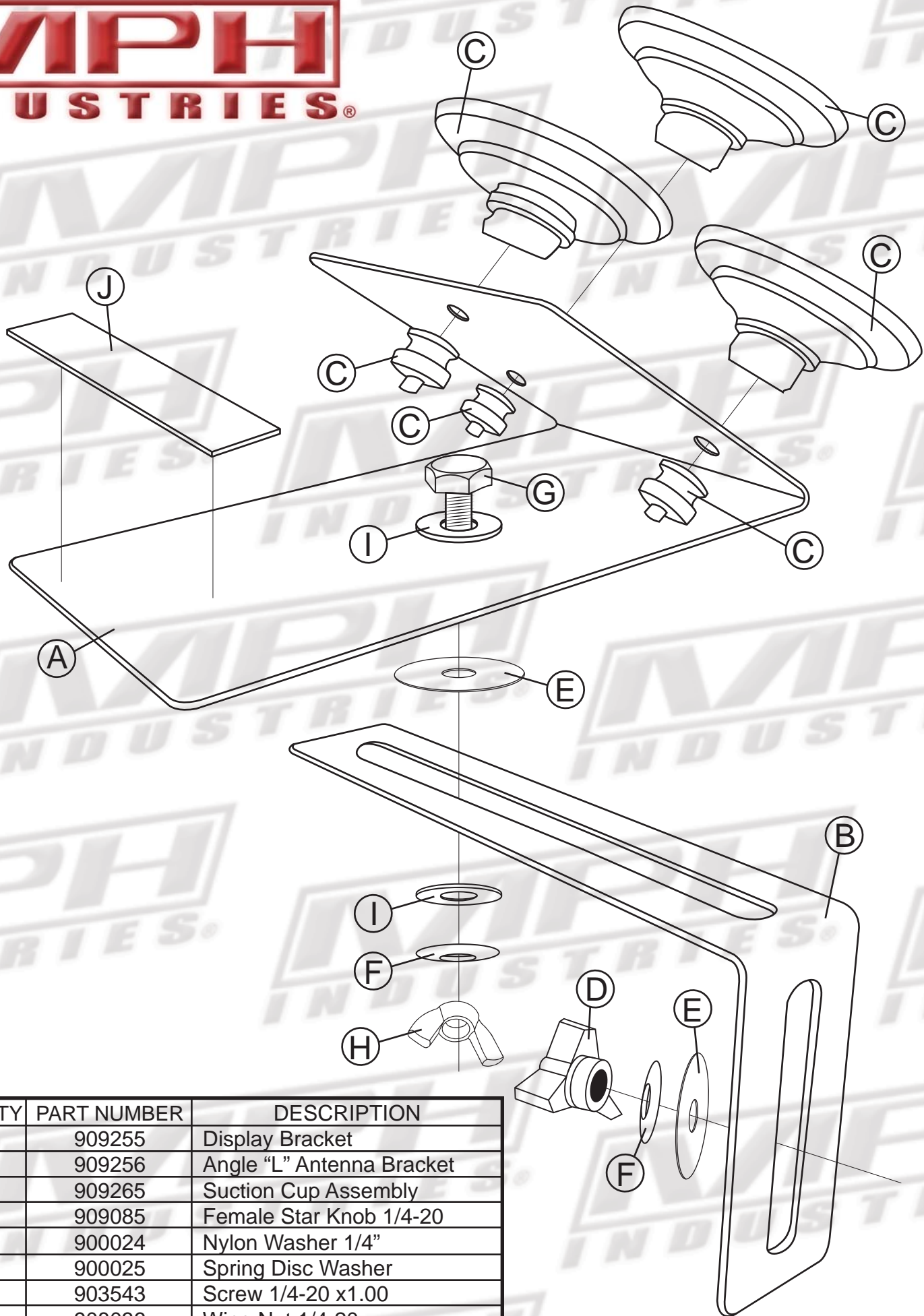

| ITEM | QUANTITY | PART NUMBER | DESCRIPTION |
|------|----------|-------------|---------------------------|
| A | 1 | 909255 | Display Bracket |
| B | 1 | 909256 | Angle "L" Antenna Bracket |
| C | 3 | 909265 | Suction Cup Assembly |
| D | 1 | 909085 | Female Star Knob 1/4-20 |
| E | 2 | 900024 | Nylon Washer 1/4" |
| F | 2 | 900025 | Spring Disc Washer |
| G | 1 | 903543 | Screw 1/4-20 x1.00 |
| H | 1 | 908036 | Wing Nut 1/4-20 |
| I | 2 | 908340 | Flat Washer 1/4" |
| J | 2.8 | 908601 | Double-Coated Tape |