

# MMPH

## INDUSTRIES®







# Installation Guide

## Ford Interceptor Display Bracket Assembly

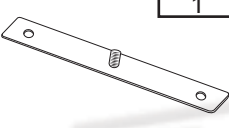
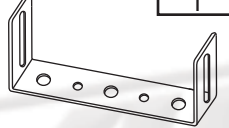
FITS: BEE III, Enforcer

PT# ai.951664

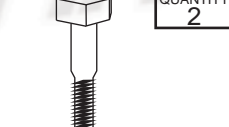
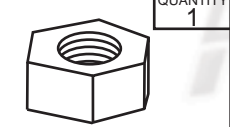
## Installation Materials

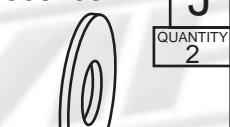
<p>910656G01</p> <p><b>A</b></p> <p>QUANTITY 1</p>  <p>Mounting Bracket</p>	<p>909351</p> <p><b>B</b></p> <p>QUANTITY 1</p>  <p>Display Bracket</p>	<p>900025</p> <p><b>C</b></p> <p>QUANTITY 3</p>  <p>Disc Spring</p>	<p>900024</p> <p><b>D</b></p> <p>QUANTITY 1</p>  <p>Nylon Washer .219 x 1.0 x .03</p>
<p>910653</p> <p><b>E</b></p> <p>QUANTITY 2</p>  <p>Fender Washer 1/4 - 1.5"</p>	<p>910658</p> <p><b>F</b></p> <p>QUANTITY 2</p>  <p>Hex Screw M6-10 x 35</p>	<p>908494</p> <p><b>G</b></p> <p>QUANTITY 1</p>  <p>Nylon Nut 1/4 - 20</p>	
<p>909094</p> <p><b>H</b></p> <p>QUANTITY 2</p>  <p>Stud Knob 10-32 x .50"</p>	<p>909092</p> <p><b>I</b></p> <p>QUANTITY 2</p>  <p>Nylon Flat Washer #10</p>	<p>908203</p> <p><b>J</b></p> <p>QUANTITY 2</p>  <p>Regular Plain Washer #10</p>	

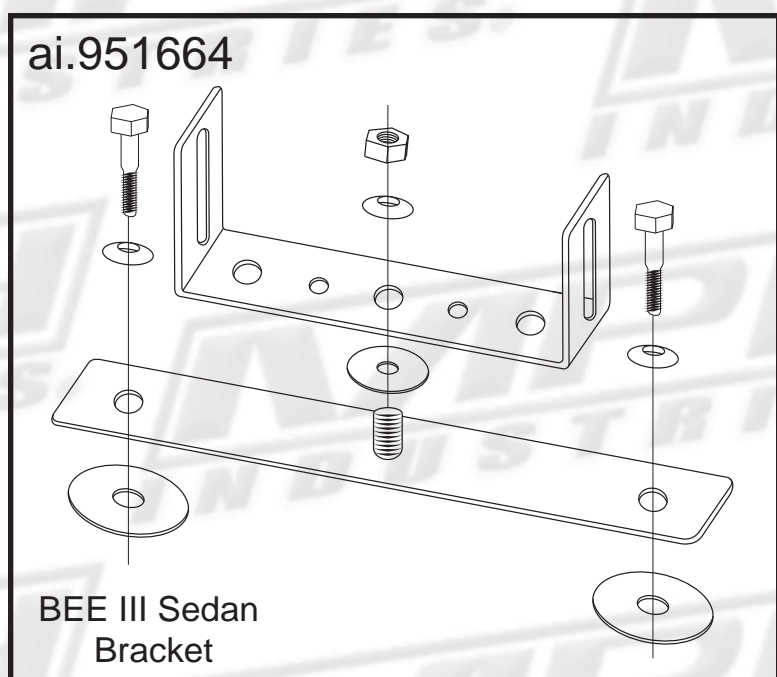

# Installation Process

**1**

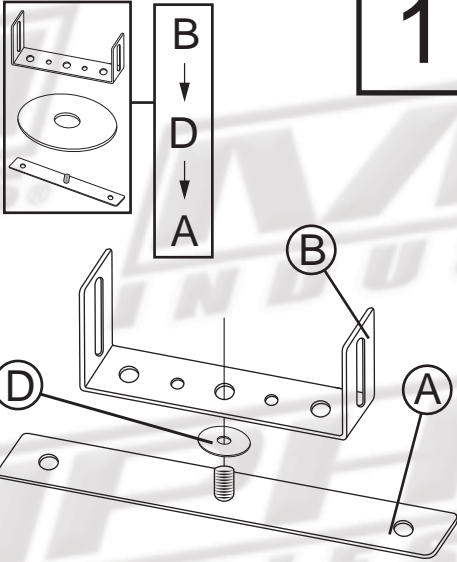

Place the Nylon Washer (D) on the stud of the Mounting Bracket (A). Take the Display Bracket (B) and put on top of the Mounting Bracket (A).

**2**

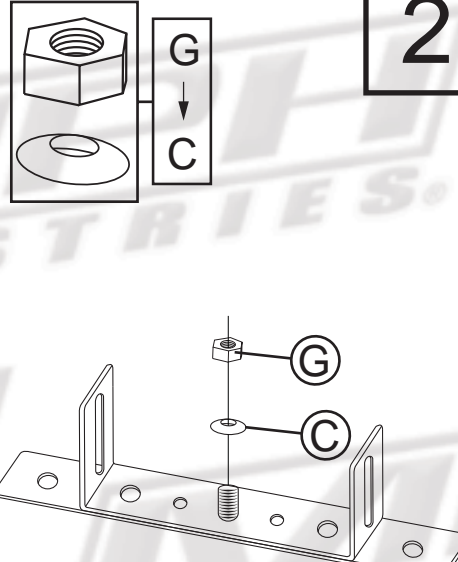

Secure the Display Bracket (B) with a Disc Spring (C) followed by the Nylon Nut (G).

**3**

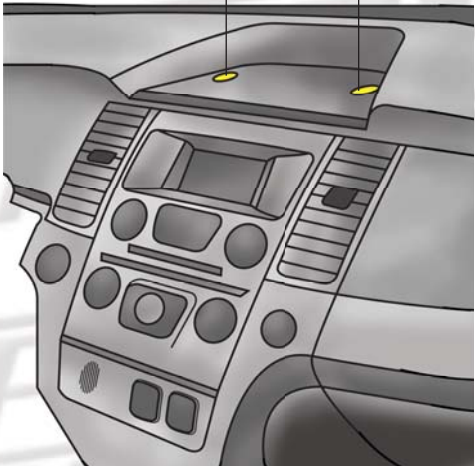

Remove bolts for bracket

The center of the dash is a tray that already has bolts installed to secure the dash safely. Remove the bolts.

**4**

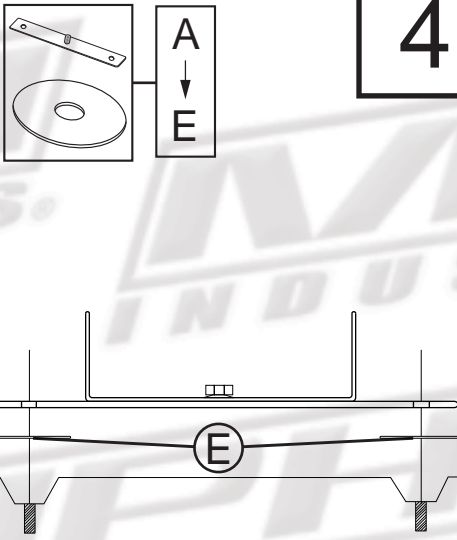

With the bolts removed on the dash tray, place a Fender Washer (E) between the dash tray and the Mounting Bracket (A) where the new bolts will be installed.

**5**

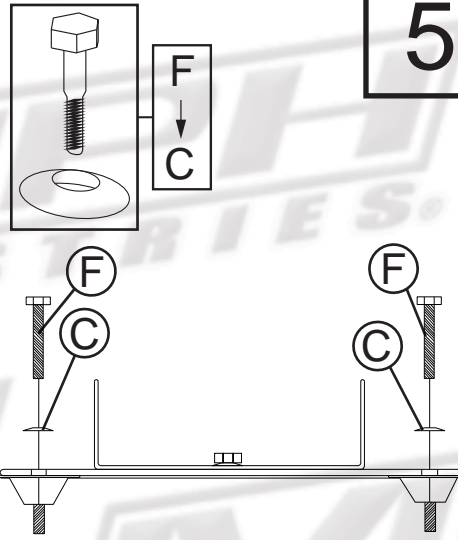

On top of the Mounting Bracket (A) put a Disc Spring (C) followed by the new Hex Screw (F) included in the kit. Secure the screws to the Dash Tray.

**6**

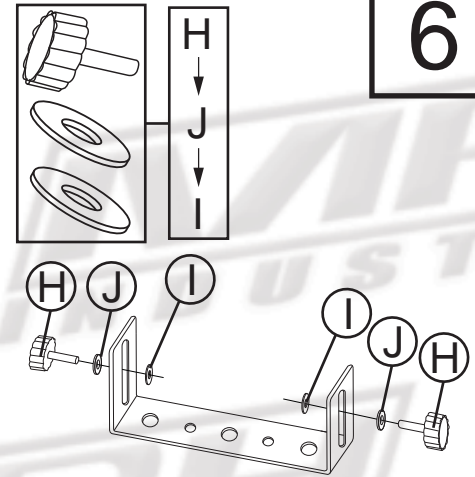

Take the BEE III readout and mount it to the Display Bracket (B) using the following order: The Stud Knob (H) then a Regular Plain Washer (J) separating the Stud Knob (H) from the Display Bracket (B). Next, put a Nylon Washer (I) on the Stud Knob (H) to separate the Display Bracket (B) and the readout. Tighten the Stud Knobs (H).

**7**

## Ford Interceptor

BEE III & Enforcer Display Bracket Assembly  
Part# ai.951664



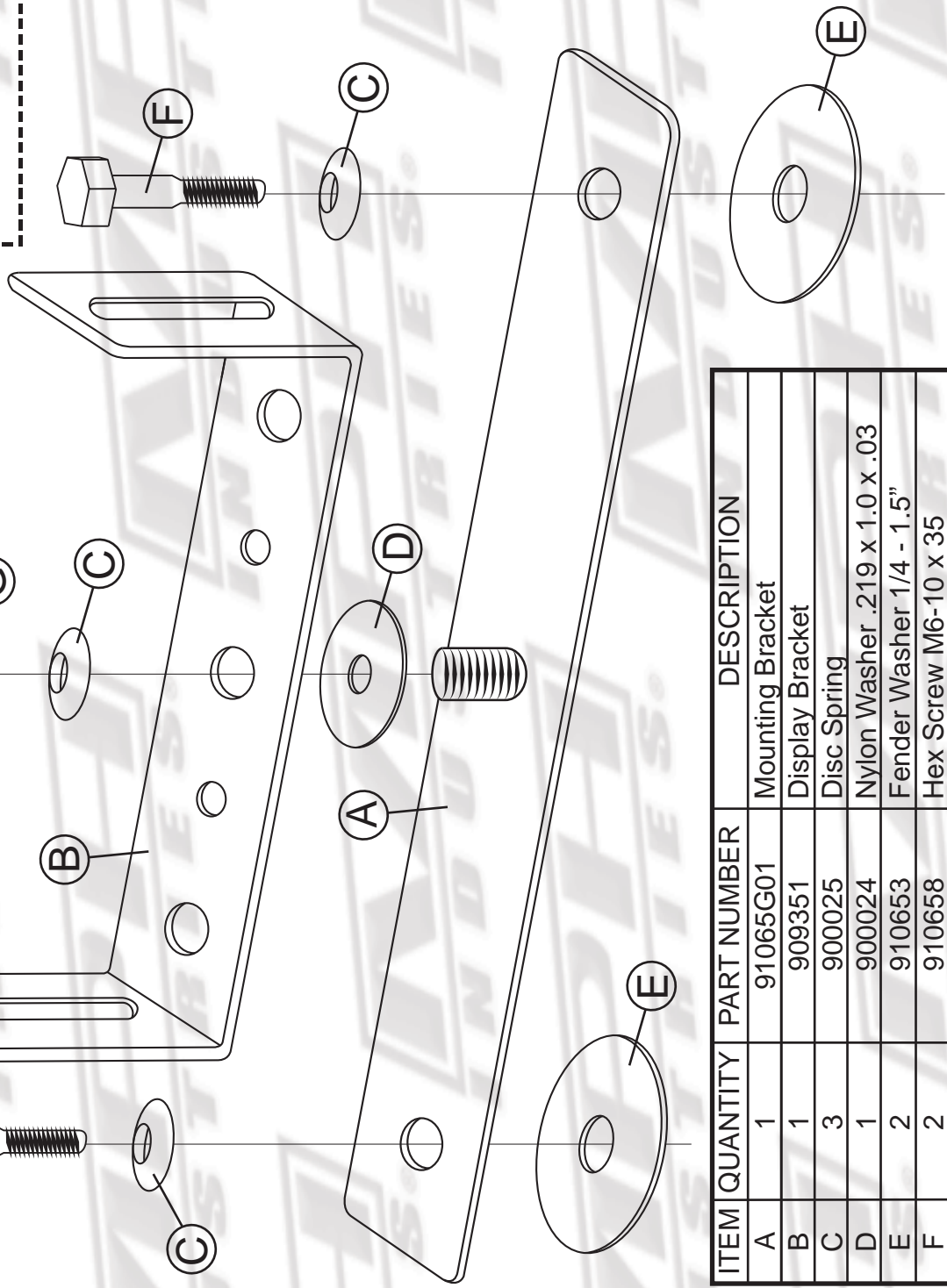
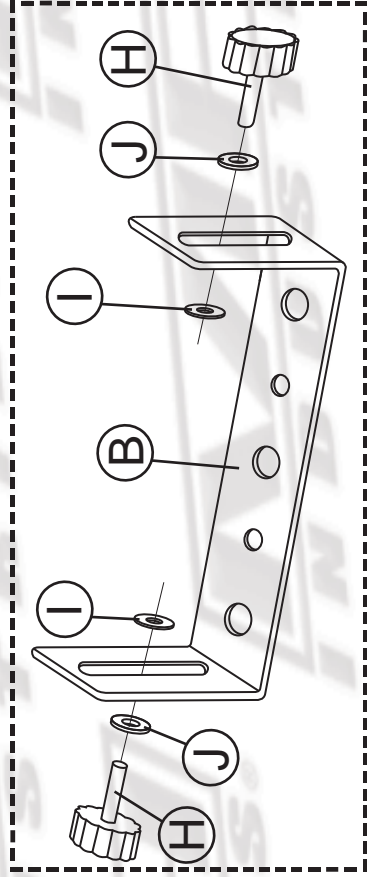

ITEM	QUANTITY	PART NUMBER	DESCRIPTION
A	1	91065G01	Mounting Bracket
B	1	909351	Display Bracket
C	3	900025	Disc Spring
D	1	900024	Nylon Washer .219 x 1.0 x .03
E	2	910653	Fender Washer 1/4 - 1.5"
F	2	910658	Hex Screw M6-10 x 35
G	1	908494	Nylon Nut 1/4-20
H	2	909094	Stud Knob 10-32 x .50"
I	2	909092	Nylon Flat Washer #10
J	2	908203	Regular Plain Washer #10

